

JT-9 Specifications:

Rotor: Diameter: 7.0 m
Blade Chord: 180 mm
Airfoil: NACA 8-H-12

Length: 3.8 m
Height: 2,4 m
Empty Weight 180 kg
Gross Weight 320 kg
Prerotation system: Electric

Engine: HKS 700
2-cylinder, 4-cycle Boxer
Power: 64 hp at 2400 rpm
Dry Sump

Performance, calculated

Rate of Climb 3 m/s
Max Speed 160 km/h
Min Speed 45 km/h

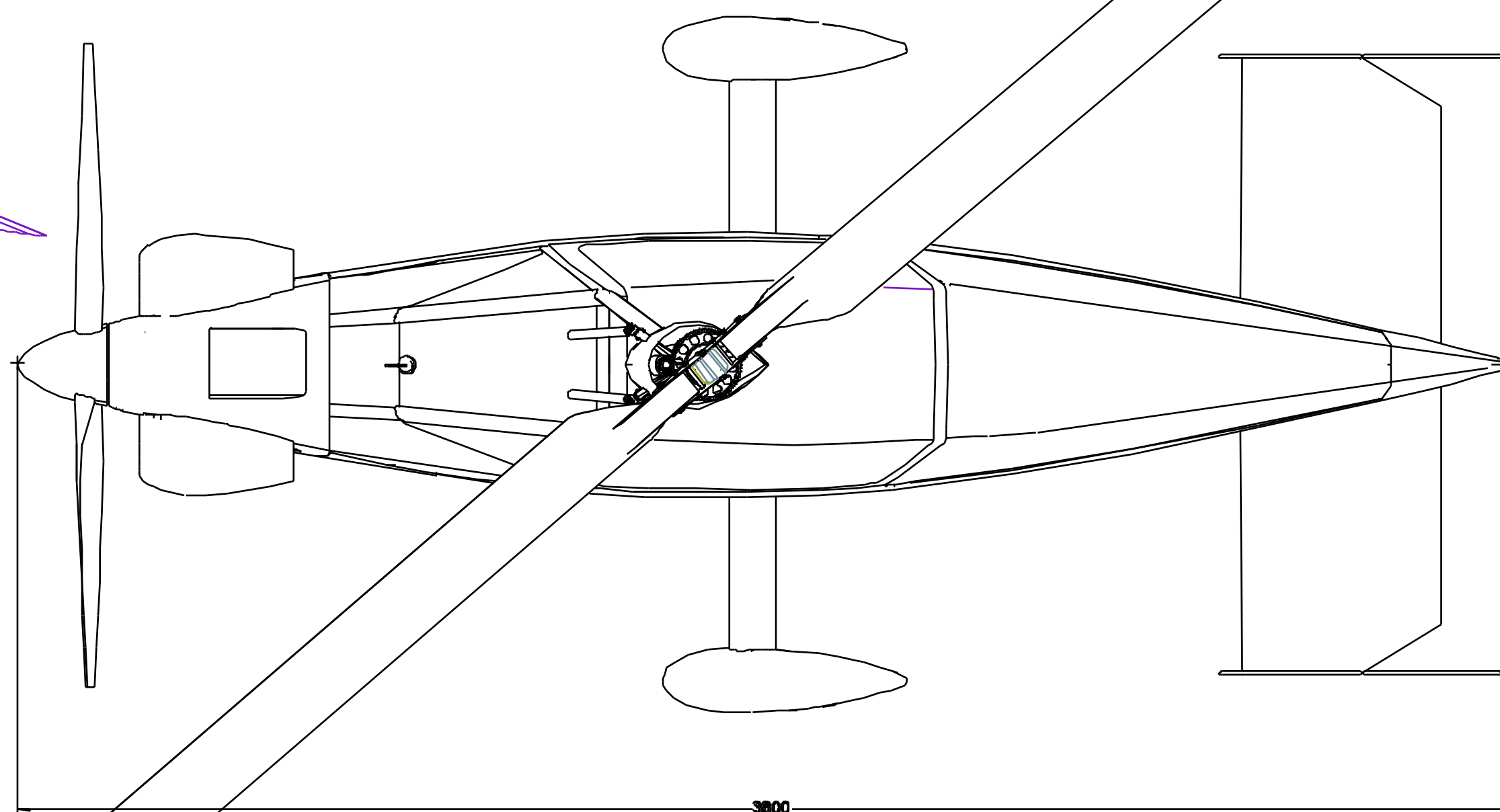
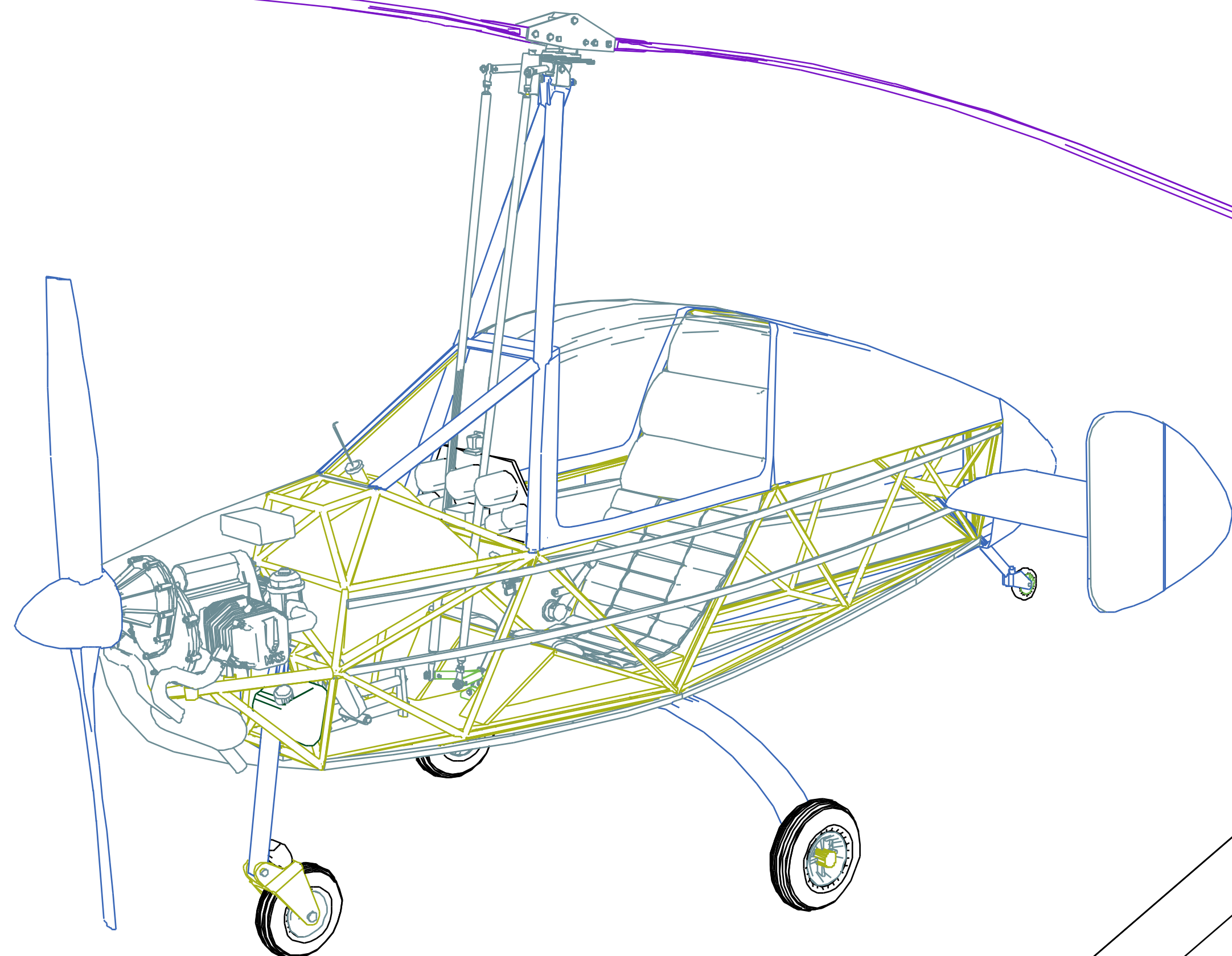
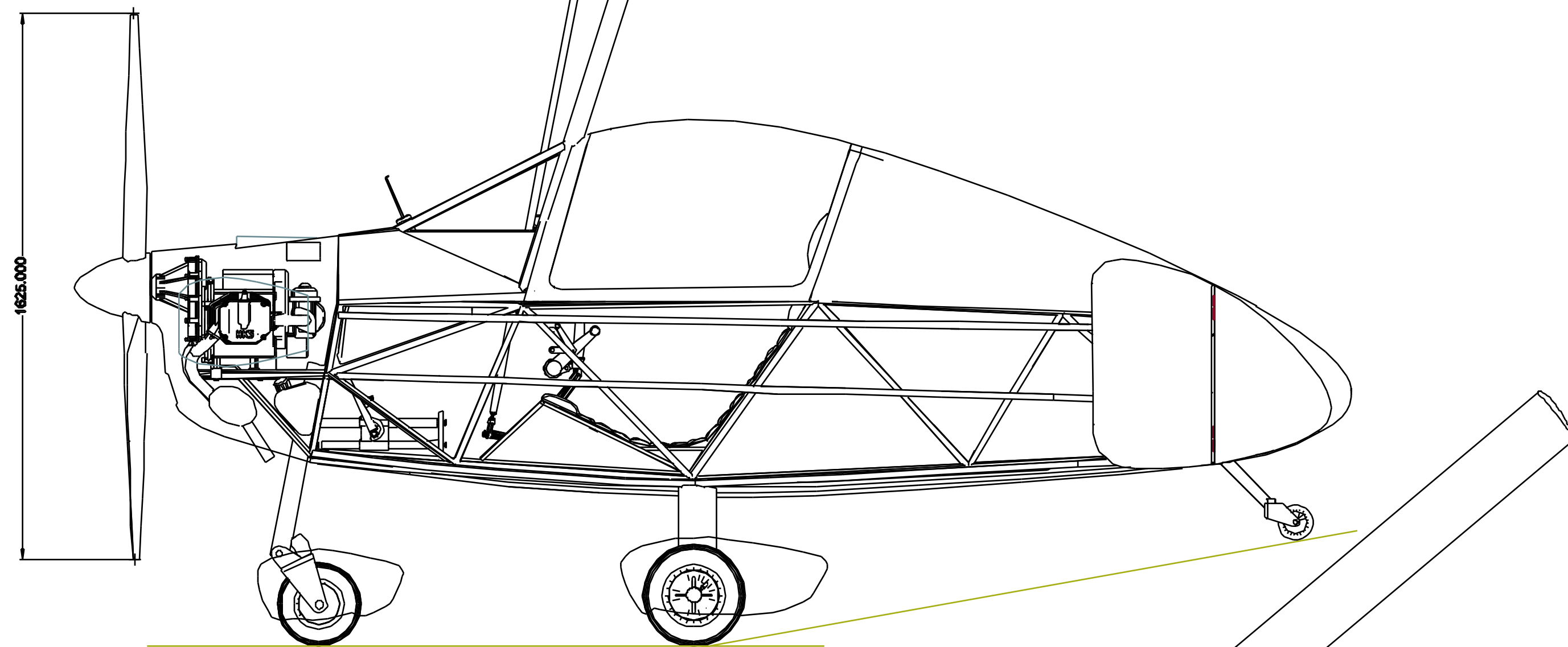
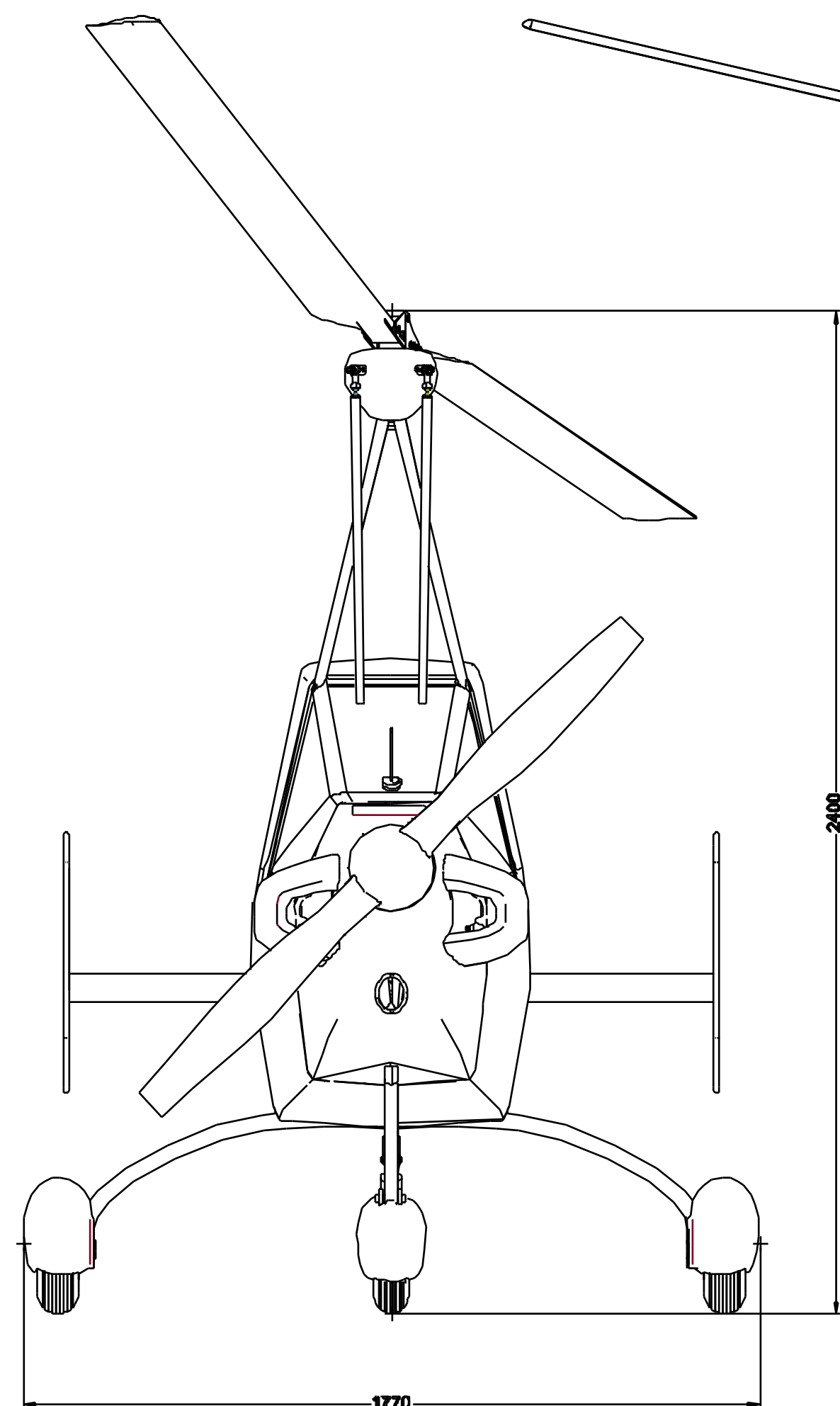

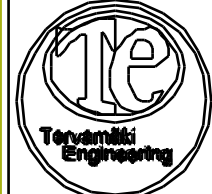
Tervämäki Engineering www.icon.fv-jtki jtki@icon.fi		Date: Nov.20.1999
		Signat. <i>Jukka Tervämäki</i>
JT-9 Autogyro General View	Scale: No Scale	